

MOFIA Initialization Branch

TWIST FLOWCHARTS

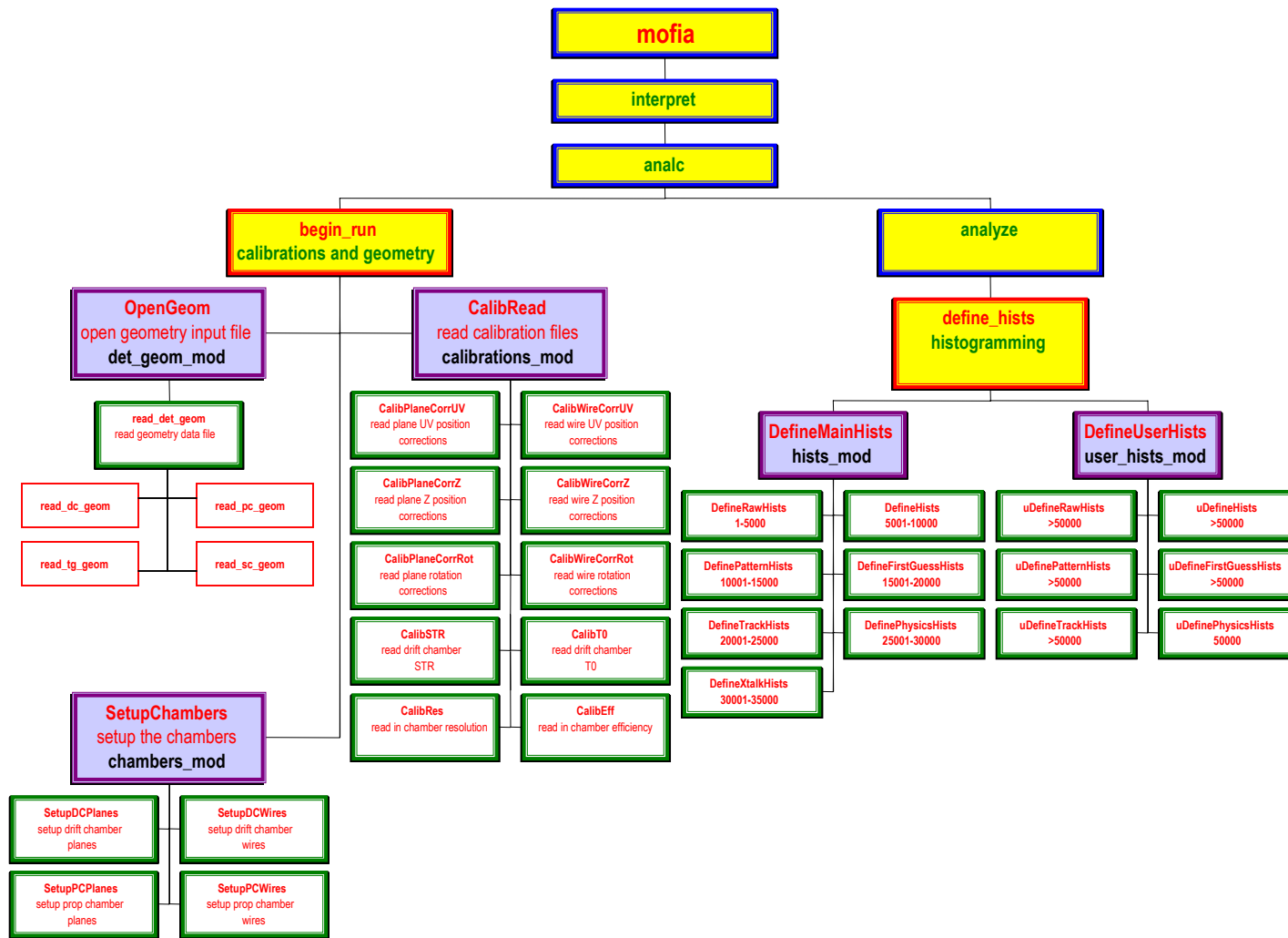

MOFIA Analysis Branch

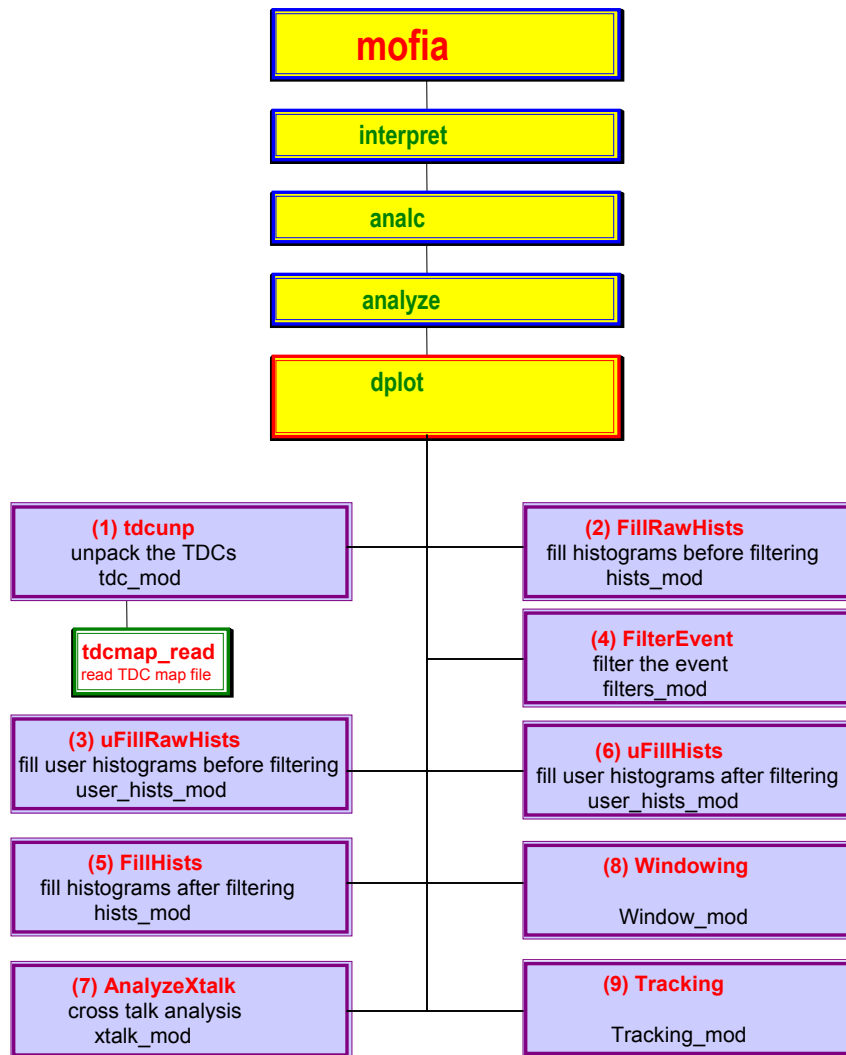

Tracking Branch

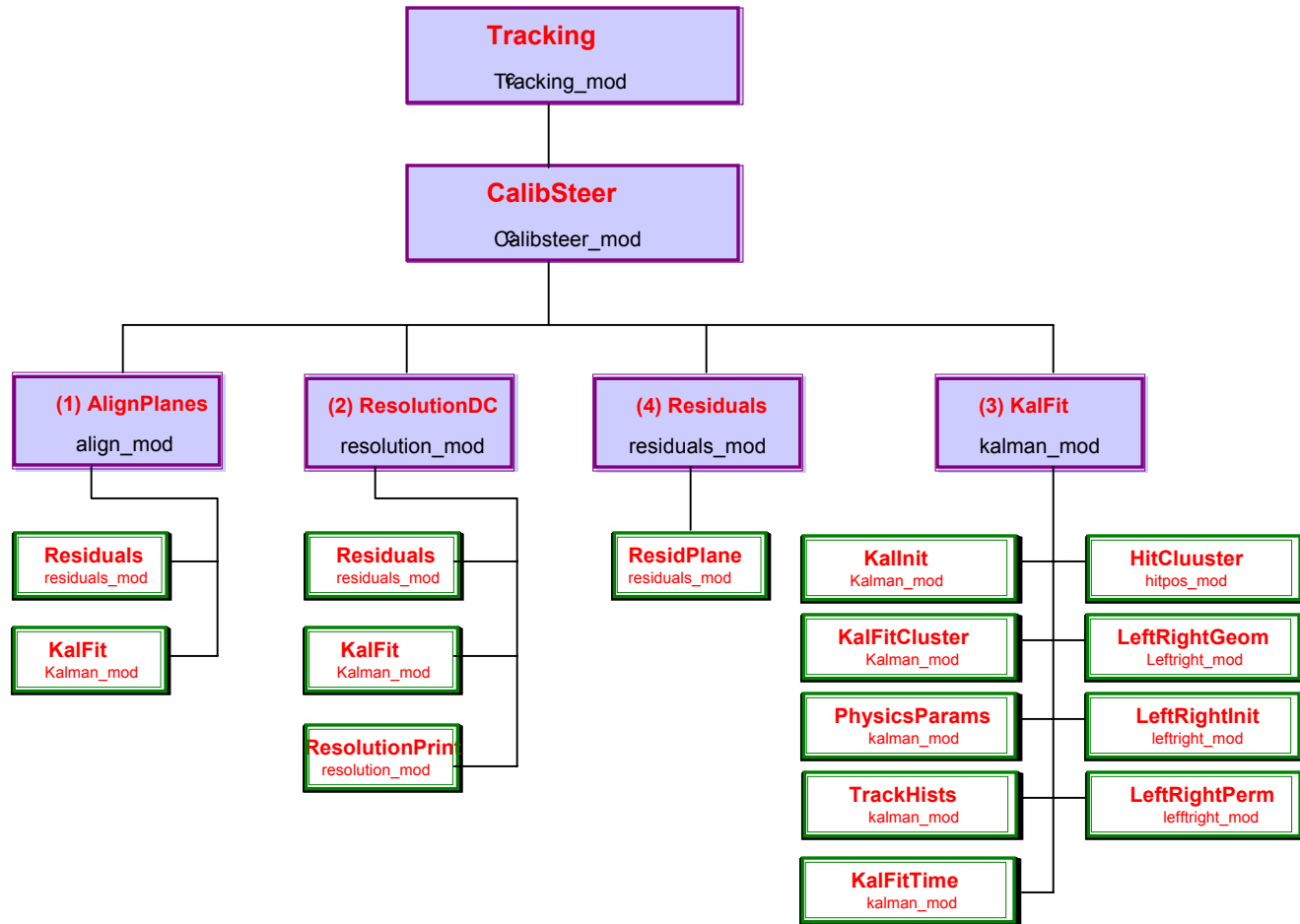

Windowing Branch

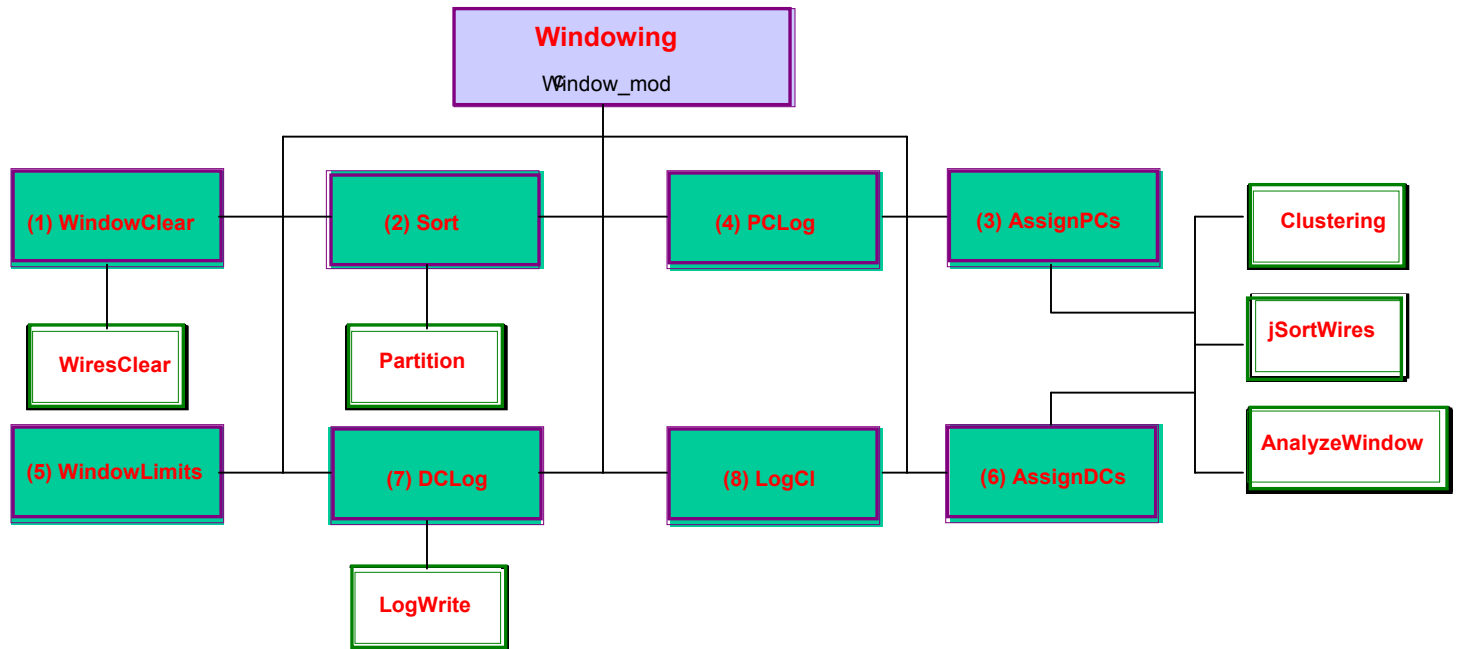

Modules List:

- tdcmap_mod
 - tdcmap_read public
 - CDGET public
 - RITE public
- tdc_mod
 - tdcfill public
 - sortwires public
 - sortwires1 private
 - insert_whit public
 - insert_whit1 private
 - tdc_init public
 - tdc_clear public
 - tdcprint public
 - whitsprint public
 - next public
 - remove_whit public
- Unp_mod
 - tdcunp public
 - tdcunp_bank private
 - * do_record private
 - tdc_listhits public
 - GetCamac public
 - unpmc public
- calibrations_mod
 - CalibRead public
 - CalibSTR private
 - CalibT0 private
 - CalibRes private

- chambers_mod
 - SetupChambers public
 - SetupDCPlanes private
 - SetupDCWires private
 - SetupPCPlanes private
 - SetupPCWires private
 - PrintGeom public
 - PrintDCPlanes private
 - PrintDCWires private
 - PrintPCPlanes private
 - PrintPCWires private
- filters_mod
 - FilterEvent public
 - CalculateCounters private
 - ApplyFilters private
 - InitAll private

- det_geom_mod
 - OpenGeom public
 - read_det_geom private
 - * read_dc_geom private
 - * read_pc_geom private
 - * read_tg_geom private
 - * read_sc_geom private
- NameList_mod
 - namelist_c public
 - show_namelist public
 - list_namelist public
- residuals_mod
 - ResidInit public
 - Residuals public
 - ResidPlane private

- **hists_mod**

- DefineMainHists public
 - DefineRawHists private
 - DefineHists private
 - DefinePatternHists private
 - DefineFirstGuessHists private
 - DefineTrackHists private
 - DefinePhysicsHists private
 - DefineXtalkHists private
- FillRawHists public
- FillHists public
- FillPatternHists public
- FillFirstGuessHists public
- FillTrackHists public
- FillPhysicsHists public
- FillXtalkHists public
- TestGeomHists public
- ResetHists public
- WriteHists public

- **user_hists_mod**

- DefineUserHists public
 - uDefineRawHists private
 - uDefineHists private
 - uDefinePatternHists private
 - uDefineFirstGuessHists private
 - uDefineTrackHists private
 - uDefinePhysicsHists private
- uFillRawHists public
- uFillHists public
- uFillPatternHists public
- uFillFirstGuessHists public
- uFillTrackHists public
- uFillPhysicsHists public

- **xtalk_mod**

- InitXtalkCounters public
- AnalyzeXtalk public
- PrintXtalkCounters public

- kalman_mod
 - KalFit public
 - KalInit private
 - KalFitCluster private
 - KalFilter private
 - » KalTrackModel private
 - KalSmooth private
 - KalFitTime private
 - KalFilter private
 - » KalTrackModel private
 - KalSmooth private
 - PhysicsParams private
 - TrackHists private
 - PRECISION_MOD
 - align_mod
 - AlignPlanes public
 - PrintResid public
 - calibsteer_mod
 - CalibSteer public
- hitpos_mod
 - HitCluster public
 - HitTime public
 - HitSegment private
 - HitPosition private
 - HitDriftBin public
- leftright_mod
 - LeftRightGeom public
 - LeftRightInit public
 - LeftRightPerm public
- efficiency_mod
 - InitEfficiency public
 - CalcEfficiency public
 - Uvpos private
 - CellNumber private
 - intersect private
 - PrintEfficiency public

- Firstguess_mod

- Particle public
 - Initialize private
 - Muon private
 - NewTrack private
 - » AddClHits private
 - » AddHits private
 - » jSortWires public
 - AddClk private
 - AddClkTmp private
 - eDense private
 - AddClk private
 - AddClkTmp private
 - eSparse private
 - NewTrack private
 - AddClk private
 - AddClkTmp private
- StartParameters public
- RemoveHits public
- CirFit private
- Cont private
- FirstGuessArt public
 - PariSearch private
 - printWorkingTrackInfo private
 - ZeroTrackCounters public
- addcluster public
 - unwind private
 - unwind4 private
 - addsums private
 - remsums private
- insert_fgtrack public
 - addtrack private
- PrintWork public
- fit_circle private
- find_slope private

- Window_mod
 - Windowing public
 - WindowClear private
 - WiresClear private
 - Sort private
 - Partition private
 - » InterchangeSort
 - AssignPCs private
 - Clustering private
 - AnalyzeWindow private
 - jSortWires public
 - AssignDCs private
 - Clustering private
 - WindowLimits private
 - DCLog private
 - LogWrite private
 - LogCl private
 - PCLog private
 - PCWLog private
 - WinLog private
 - DinSertLog private
 - LogWinHits private
 - WireLog private
 - WinTmpLog private
- Track_mod
 - TrackLog public
 - insertmctrack public
 - listmctracks public
 - difMCFGtracks public
 - diftracks private
- matrix_mod
 - MatrixMultiply public
 - MatrixTranspose public
 - MatrixInvert public
 - test_matrix public
- resolution_mod
 - ResolutionDC public
 - ResolutionPrint public
 - ResolutionInit public
- Tracking_mod
 - Tracking public

FW-OF
 1 2 3 4 5 6
 7 8 9 10 11 12
 13 14 15 16 17 18
 19 20 21 22 23 24
 25 26 27 28 29 30
 31 32 33 34 35 36
 37 38 39 40 41 42
 43 44 45 46 47 48
 49 50 51 52 53 54
 55 56 57 58 59 60
 61 62 63 64 65 66
 67 68 69 70 71 72
 73 74 75 76 77 78
 79 80 81 82 83 84
 85 86 87 88 89 90
 91 92 93 94 95 96
 97 98 99 100

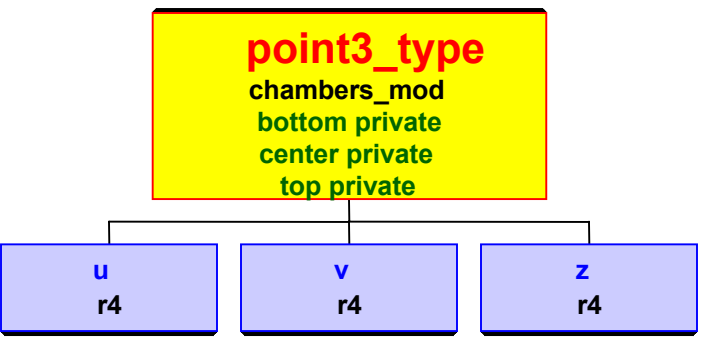
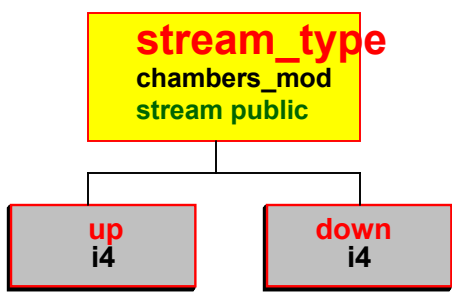
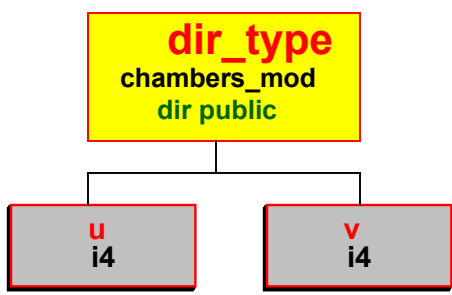
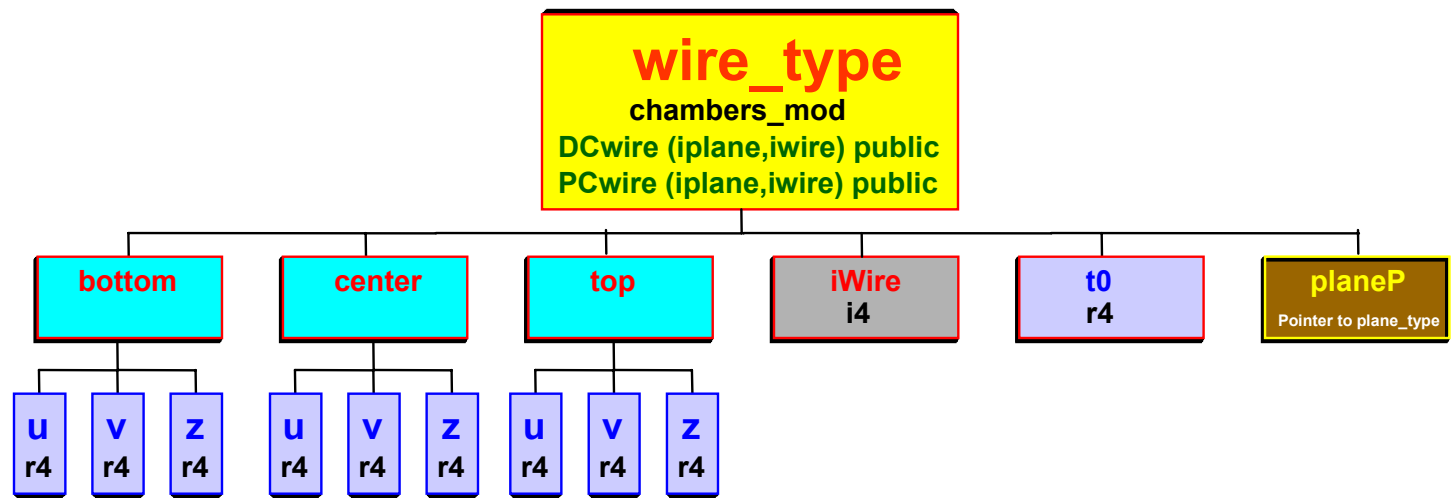
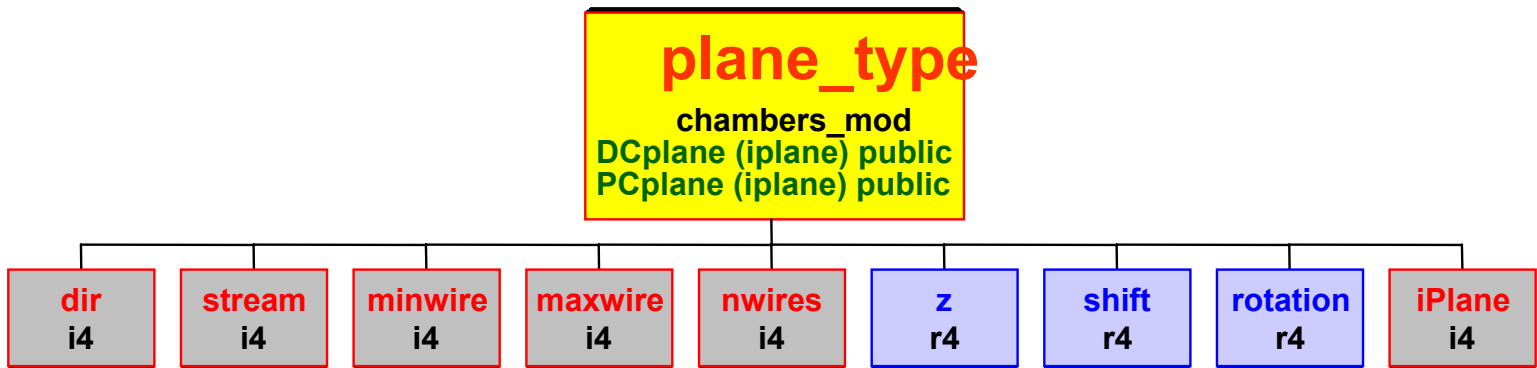

FW-01-01-02-03-04-05-06-07-08-09-10-11-12-13-14-15-16-17-18-19-20-21-22-23-24-25-26-27-28-29-30-31-32-33-34-35-36-37-38-39-40-41-42-43-44-45-46-47-48-49-50-51-52-53-54-55-56-57-58-59-60-61-62-63-64-65-66-67-68-69-70-71-72-73-74-75-76-77-78-79-80-81-82-83-84-85-86-87-88-89-90-91-92-93-94-95-96-97-98-99-100

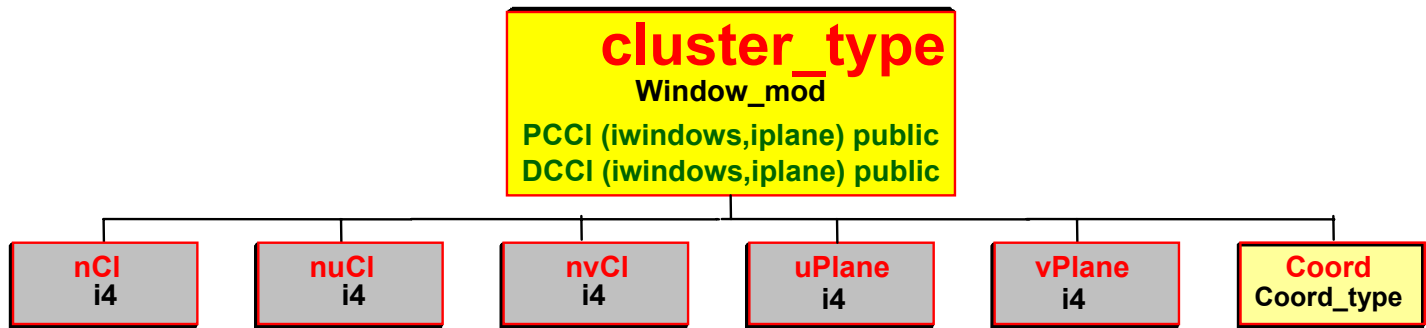
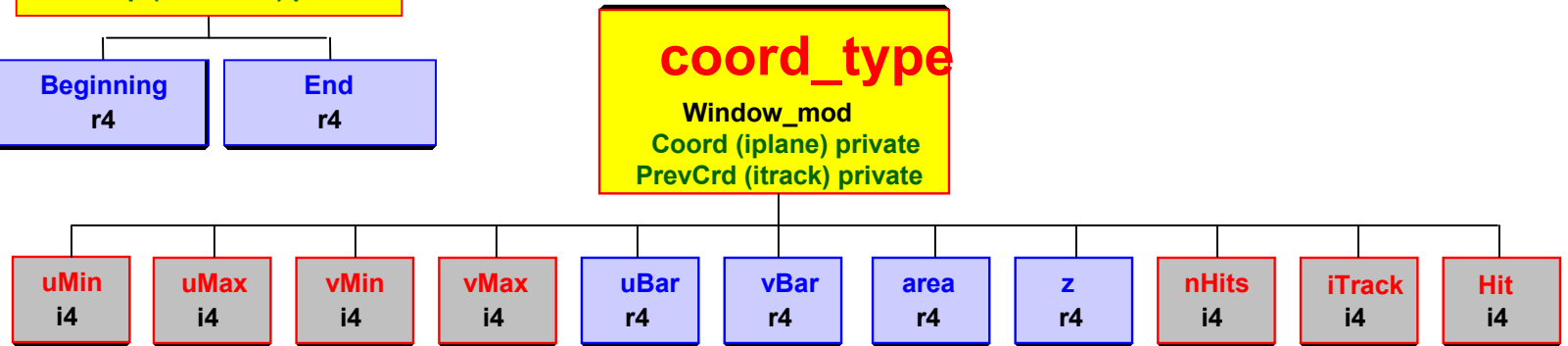
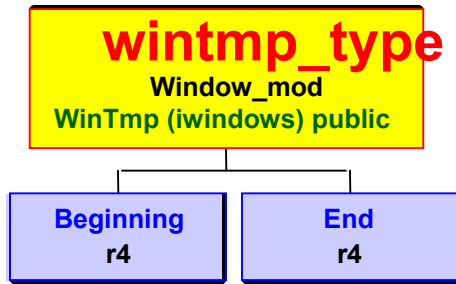
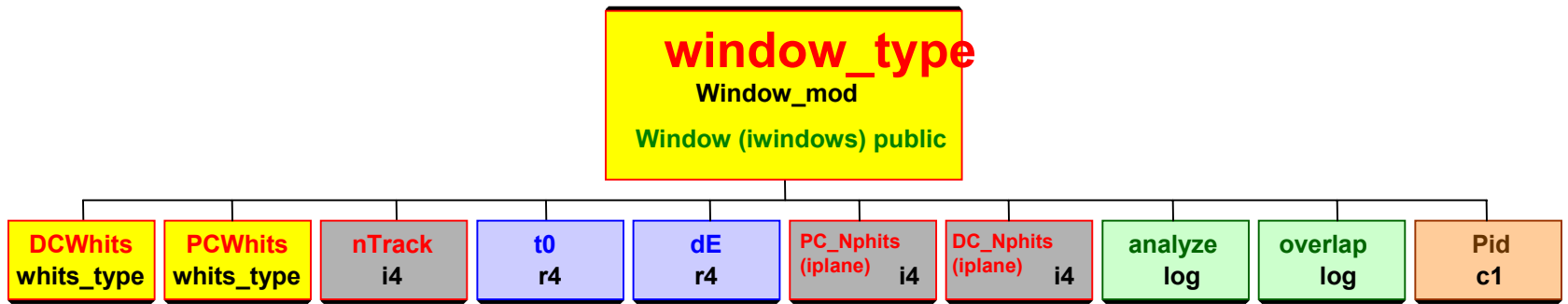

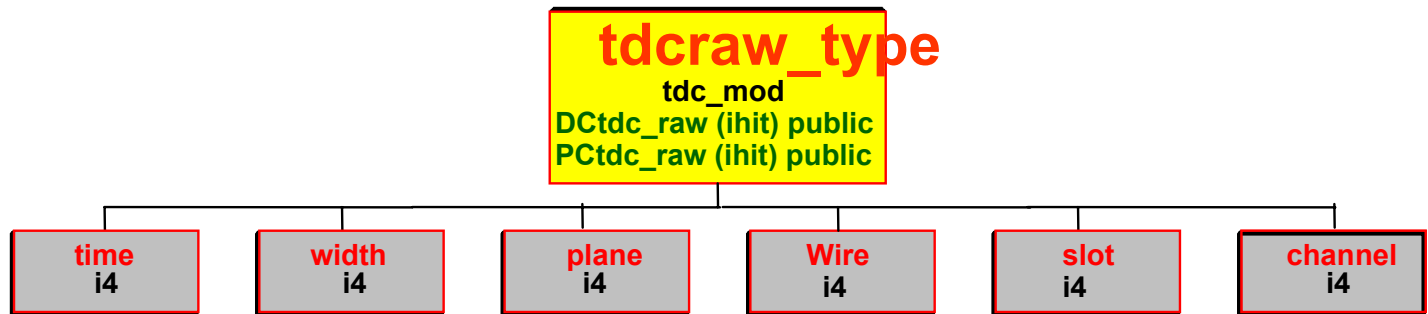
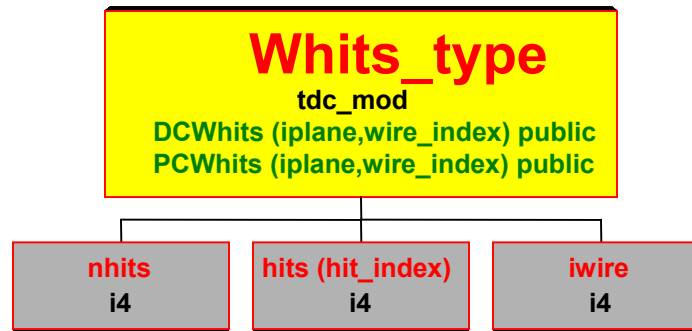
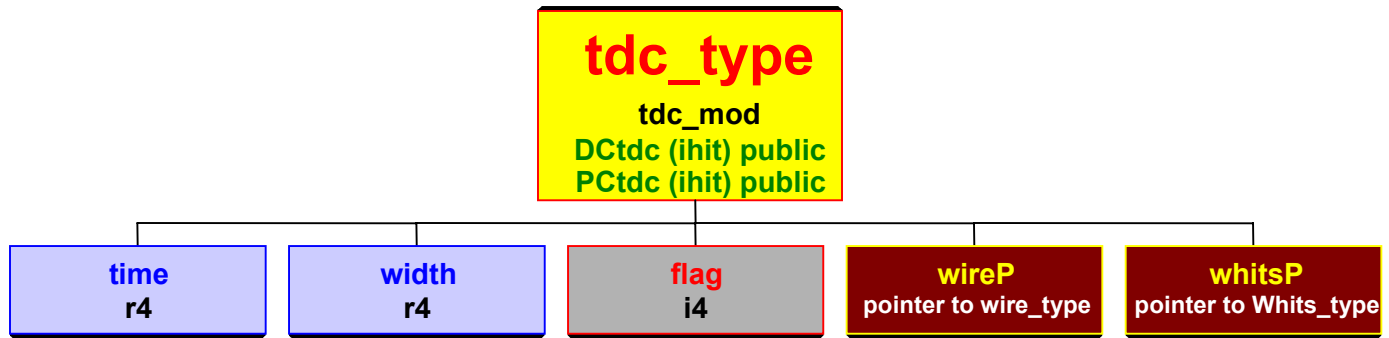

FW-01
 1
 2
 3
 4
 5
 6
 7
 8
 9
 10
 11
 12
 13
 14
 15
 16
 17
 18
 19
 20
 21
 22
 23
 24
 25
 26
 27
 28
 29
 30
 31
 32
 33
 34
 35
 36
 37
 38
 39
 40
 41
 42
 43
 44
 45
 46
 47
 48
 49
 50

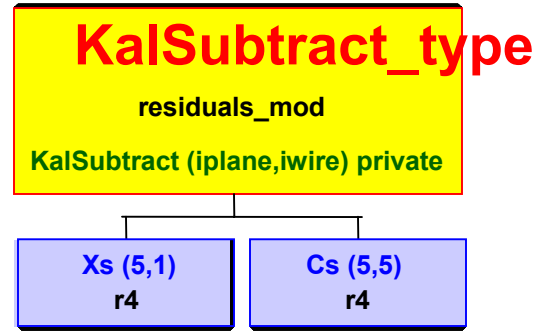
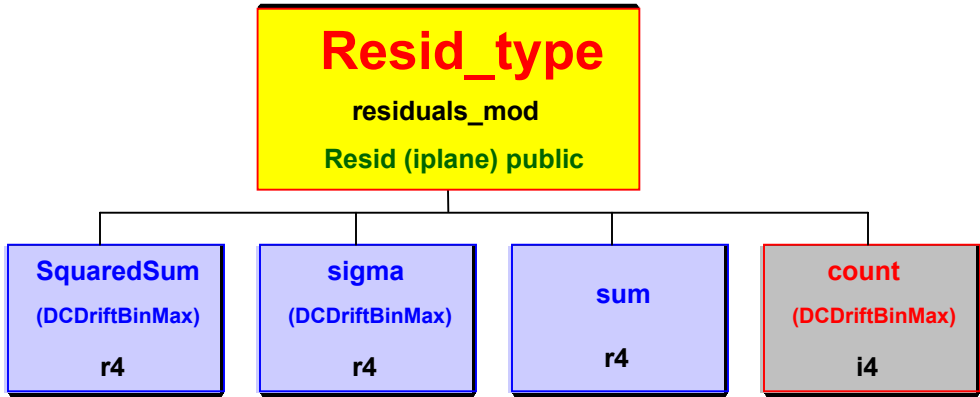
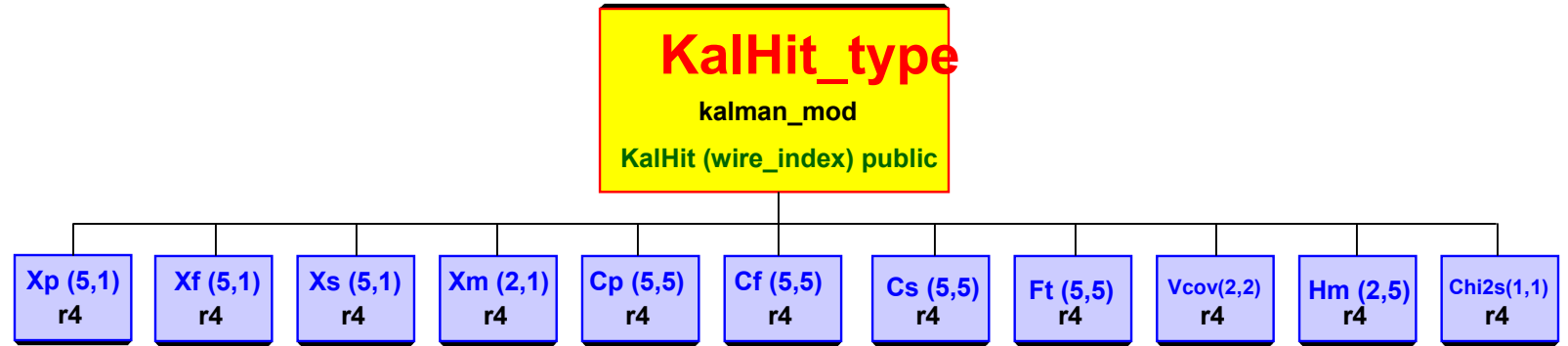
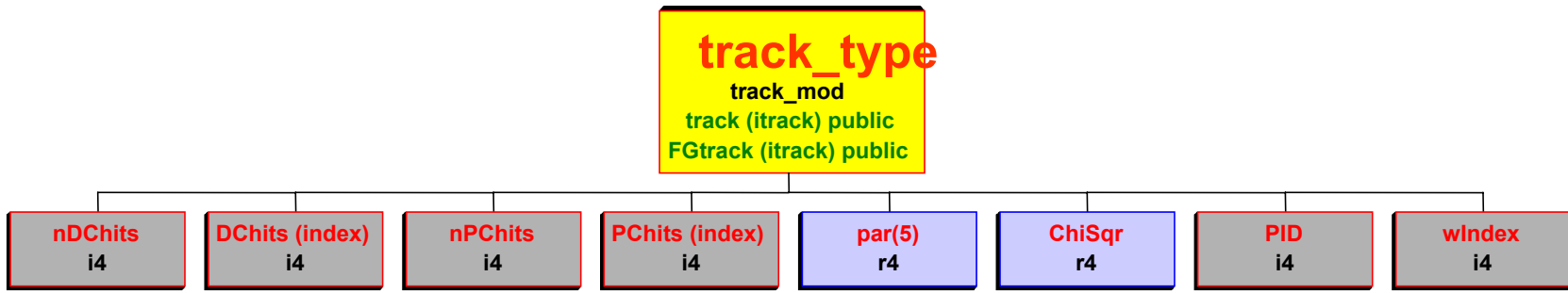

FW-01
 1
 2
 3
 4
 5
 6
 7
 8
 9
 10
 11
 12
 13
 14
 15

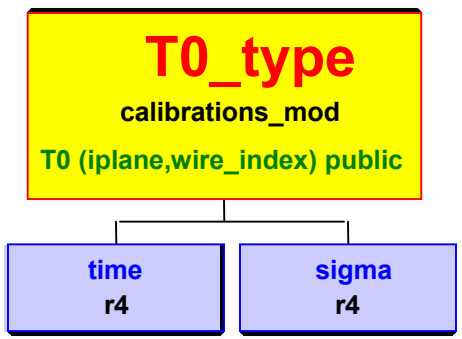
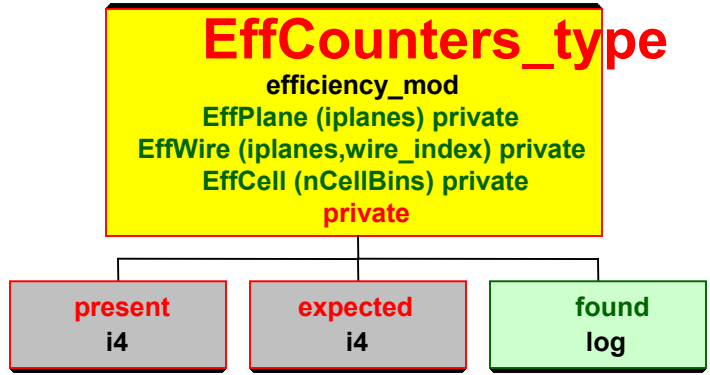
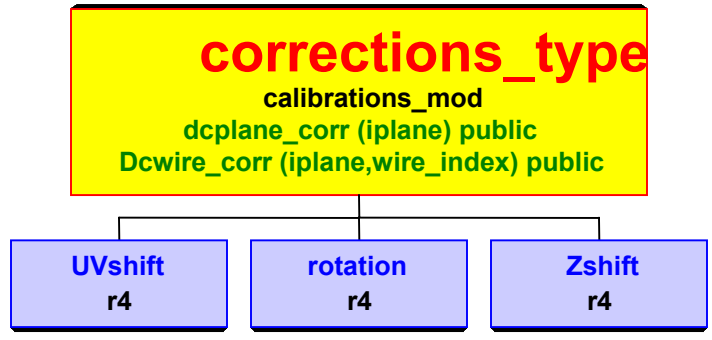
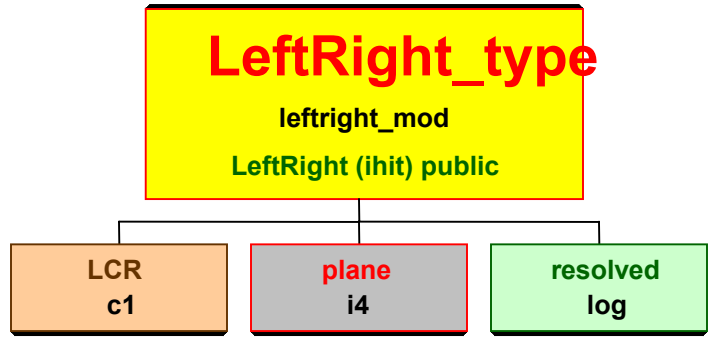
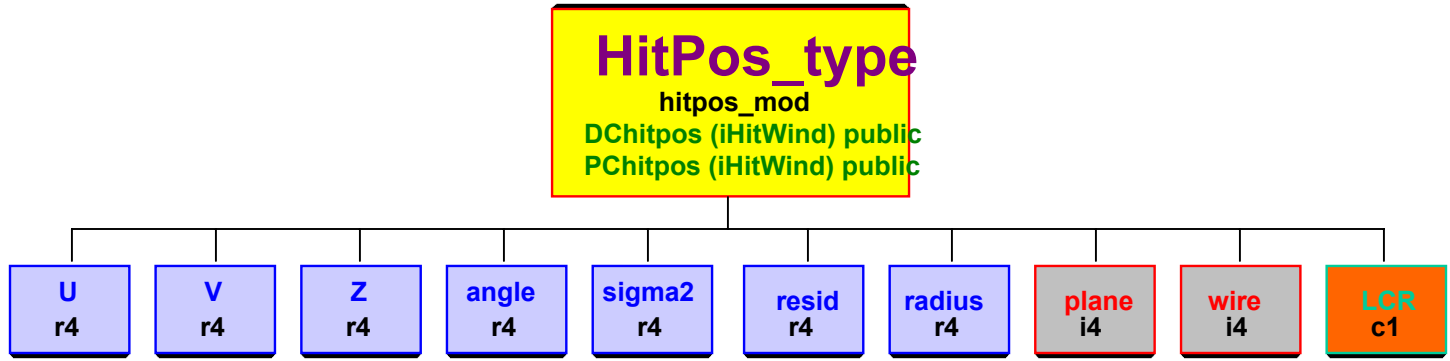

FW-01
 15
 16
 17
 18
 19
 20
 21
 22
 23
 24
 25
 26
 27
 28
 29
 30
 31
 32

